

ORIGINAL INSTRUCTIONS

G84-LS

Split Riveter



MANUAL



CHERRY[®]
AEROSPACE
SPS Fastener Division, a PCC Company

1224 E. Warner Ave
Santa Ana, CA 92705
www.cherryaerospace.com

THE CHERRY® G84-LS SPLIT RIVETER TABLE OF CONTENTS

Technical Specifications	2
Recommended Usage.....	3
Reconfiguring for Pistol Grip or In-Line operation	3
Operational Safety Warnings.....	3
Maintenance and Repair.....	4
Recommended Fluid	4
Dexron III Oil Safety Data	4
Protecting the High Pressure Hoses	5
Un-wrapping Hoses	5
Fill and Bleed Instructions	5
Replenishing the Hydraulic System with Fluid.....	5
Bleeding	6
Tool Overhaul	6
Assembly of Double Delta Air Valve Sub-Assembly.....	6
Head Sub-Assembly	7
Handle Sub-Assembly.....	7
Tool Care.....	8
Troubleshooting	8
Parts List.....	9
Exploded View	10
Cross Section Drawings.....	11
Declaration of conformity	Back Cover
Warranty	Back Cover

DESCRIPTION

The G84-LS is a powerful, rugged, compact split riveter designed for ergonomic, high speed and reliable operation. Adaptors are available for mounting most Cherry pulling heads; it will install most popular sizes and types of aircraft pull type fasteners including lock-bolts, blind-bolts, etc.

This tool may be configured for comfortable left hand, right hand, in-line or pistol-grip operation. The trigger handle may also be positioned away from the head assembly, for remote activation (similar to the G84-LSR). This allows for superior ergonomics and greater accessibility in obstructed applications.

TECHNICAL SPECIFICATIONS

Specifications shown herein are subject to change also
Contact us for the latest information available on any

SPECIFICATIONS:

OPERATING AIR PRESSURE 90 to 110 psi (6,2 -7,6 bar)

AIR QUALITY Clean, Filtered

HOSE LENGTH 10 Ft. (3,05 m)

PISTON STROKE 0.530 inch (13,5 mm)

PULLING FORCE 5,700 lbs. @ 110 psi
(25,35 kN @ 6,9 bar)

RETURN FORCE 2000 Lbs max.
(8,89 kN max)

WEIGHT

HAND HELD UNIT 3.0 lbs. (1,3 kg)

TOTAL 11.8 lbs. (5,3 kg)

NOISE LEVEL 66.5 dB (A)

VIBRATION 4.0 m/s²

AIR CONSUMPTION 0.34 SCF/cycle
(9,63 L/cycle)

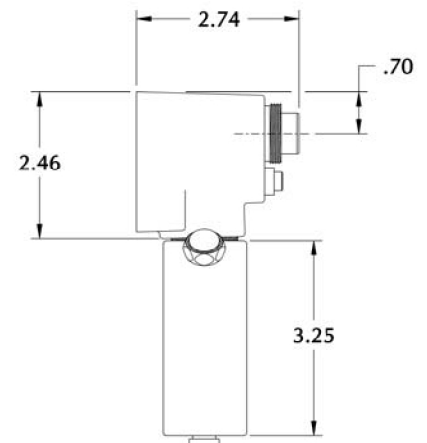
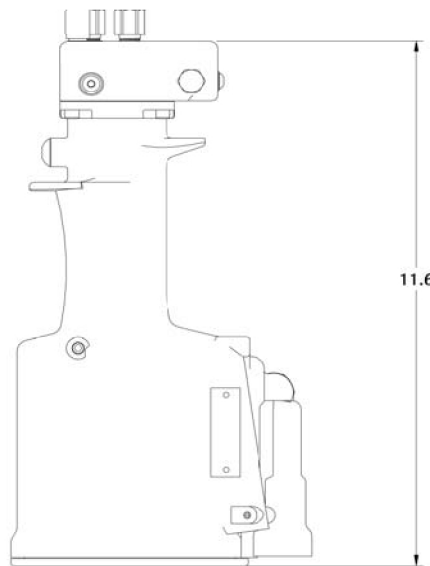

RECOMMENDED USAGE

This Riveter is designed to install pull type fasteners in conjunction with compatible pulling heads.

Pulling heads suitable for G84-LSR or comparable riveters will mount directly with no adaptation. Most Cherry® pulling heads may be used with appropriate adaptation (see table). Note: The unit may be used for other applications if it operates within the given parameters, and appropriate safety precautions have been taken.

Contact Cherry® Technical Services for more information.

Adapter	To Adapt to Tool Mounting System
744-500	Cherry® G744 mount
744-600	Cherry® G704B/747/746A
744-700	Cherry® G83/G84 Bayonet

PULLING HEAD INSTALLATION:

Connect air source prior to mounting any pulling head; mount per manufacturer instructions.

RIVETER OPERATION

Hold the handle firmly and depress the trigger.

Once the operation is completed, release trigger.

The tool may be configured prior to use for In-Line or Pistol Grip (figures 1 and 2) as necessary; see below for instructions. It may also be configured for remote activation (similar to G84-LSR)

OPERATIONAL SAFETY WARNINGS

- Tool must be operated, repaired and maintained only by trained personnel
- Make sure pulling head and riveter are in good working condition; operating a defective unit will lead to hazardous conditions
- Ensure that the air vent holes are not obstructed and that the fittings, hydraulic hoses and wrapping are in good working condition
- Use approved eye protection at all times while operating or performing maintenance on this tool
- Use appropriate personal protection equipment for the environment the tool operates within.
- Use stem deflector 530A16 with plug 744-503 when installing break stem fasteners with straight pulling heads (broken stems may exit this configuration at high velocity)
- Make sure that the selected pulling head is mounted correctly and equipped with appropriate safety features. Do not operate with a damaged stem deflector.
- Use only within the given operating capability
- Do not exceed the recommended air pressure.
- Never point the tool or pulling head towards any person
- Before disassembling the tool read the maintenance and repair instructions carefully
- Always disconnect from the air source before servicing, adjusting.
- Do not use substitutes for components. Modifications are at customer's entire risk and responsibility.
- Avoid excessive contact with the fluid to avoid the possibility of skin rashes; wear rubber gloves if necessary. Wash thoroughly after contact with the fluid.
- Do not pound on the rear of the head cylinder (744-150) to force fasteners into holes as this will damage the tool
- Altering the riveter configuration in any way outside of the current instructions is not acceptable.
- Direct tool operation and safety questions and concerns to Cherry®

RECONFIGURING TOOL GRIP FOR ACCESSIBILITY

Inline (figure 1), Pistol Grip (figure 2) as well as Left/Right Handed configuration are possible. The standard factory configuration is Pistol Grip, Right Hand operation.

The handle may also be moved away from the head assembly for remote activation (similar to the old G84-LSR).

To reconfigure for in-line operation (refer to Parts List and Exploded View on pages 9):

1. Remove the air source and place head cylinder higher than the power unit, over a pan to contain fluid spills.
2. Pull some of the hose wrap from under the handle grip (figure 3)
3. Slide hand grip (80) away from the head (figure 4), identify "P" from "R" hose and unthread the fittings.
4. Remove plugs (69); thread and tighten the hose fittings in their place making sure to match the P and R ports with the right hoses.
5. Thread the plugs (69) into the vacated holes and tighten them securely.
6. Fill and bleed per page 5.

CAUTION: This operation to be performed by trained personnel only!



Figure 3



Figure 4

MAINTENANCE AND REPAIR

Note: Minor fluid loss over time at the piston rod is normal, and does not indicate seal damage.

See troubleshooting guide (page 8) for simple tips on when tool maintenance or repair is necessary.

- Always remove the air source from the tools prior to performing any maintenance work.
- Establish a maintenance schedule according to your production needs to ensure optimum riveter operation
- Inspect routinely for fluid leaks around plugs, screws and fittings, moving parts.

RECOMMENDED FLUID

Automatic transmission fluid, Dexron® III (no substitutes).

PROPERTIES: Specific gravity: 0.863

Weight per gallon: 7.18 lbs.

Open flash point: >200°C (392°F)

RECOMMENDED BRAND: ATF Dexron® III. The data herein is for your reference; for the latest MSDS, check with the fluid manufacturer.

DEXRON III® FLUID SAFETY DATA

HANDLING: Eye protection required. Protective gloves, chemical-resistant boots and apron are recommended.
Use in well ventilated area.

FIRST AID

If irritation develops, please consult a physician.

Skin: Wash thoroughly with soap and water as soon as possible. Casual contact requires no immediate attention.

Eyes: Flush with abundant water.

Ingestion: Seek medical attention immediately.
DO NOT INDUCE VOMITING.

Inhalation: Remove from contaminated area; apply artificial respiration if needed. If unconscious, consult physician.
No significant adverse health effects expected from short term exposure.

ENVIRONMENT

Storage: Avoid storage near any ignition source, including open flame

Waste Disposal: In accordance with applicable regulations.

Spillage: Prevent entry into drains, sewers and water courses. Soak up with diatomaceous earth or other inert material. Dispose in accordance with applicable regulations.

Combustibility: Slightly combustible if heated above flash point. It will release flammable vapors which can ignite or be explosive in confined spaces if exposed to source of ignition.

Fire: Use suitable extinguishing media: dry powder, foam, and CO2 or water fog. Do not use water jets.

PROTECTING THE HIGH PRESSURE HOSES



Figure 5



Figure 6



Figure 7



Figure 8



Figure 9



Figure 10

TOOLS NEEDED: P1444

PROCEDURE:

- Follow step in figures 5 through 10; hold the installed wrap with one hand, while sliding the tool P1444 over the entire hose length (similar to using a zipper) to complete the operation.
- Wrap tape around the 2 ends of the wrap.

UN-WRAPPING HYDRAULIC HOSES

Figure 12: Unwrap the tape then pull the wrap sideways starting from one end (figure 11).



Figure 11

FILL AND BLEED



Figure 12



Figure 13



Figure 14



Figure 15

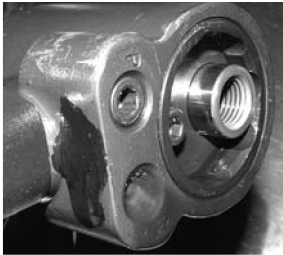

Figure 16



Figure 17



Figure 18



Figure 19



Figure 20

Required tools: Pressurized oil source with correct fitting (#10-32)

A. Replenishing the fluid (refer to page 9 for Component List)

This operation is necessary when a major fluid loss occurred.

- Connect to an air source
- Depress and hold the trigger; disconnect from the air source while holding the trigger depressed.
- Make sure the piston is fully retracted; if not, press it manually.
- Figure 12: Remove the screws (33) from the side and back of manifold (35)
- Figure 13: Thread a pressurized fluid source into the side hole; pump fluid until it flows out smoothly, without any bubbles.
- Figure 14: Thread and tighten the cap screw.
- Figure 15: Remove "R" plug (69) from the head cylinder
- Figure 16: Pump fluid until it flows smoothly, without air bubbles
- Figure 17: Thread in and tighten "R" plug (69) and remove "P" plug (69).
- Figure 18: Place a cloth over the head cylinder to contain the air and fluid that will squirt out of the "R" port
- Figure 19: Connect ratchet to an air source and then remove cloth
- Figure 20: Pump fluid until it flows smoothly with no air bubbles
- Thread-in and tighten the "P" plug (69); bleed per instructions given below.

B. Bleeding Instructions (air removal and fluid refill for an already primed tool):

- Required tools: Air Bleeder P/N 700A77.

Procedure:



- Remove screw (33) and attach the air bleeder (700A77)
- Connect ratchet to an air source
- Place the handle subassembly (744-189) sideways in a vise, with the head casting (744-202) placed below it; make sure that the air bleeder is up-side down (see picture on the right).
- Push and release trigger several times, observing the fluid inside the Bleeder bottle; repeat until no air bubbles are observed in the bottle during operation



- Disconnect the air bleeder and seal by tightening screw (33)
Caution: Do not depress the trigger before the screw (33) is tightened.

TOOL OVERHAUL

Tool overhaul is needed in case of tool malfunction, massive fluid loss or as part of your routine maintenance program.

TOOLS NEEDED: G84-LSKT – tool kit,
Needle Nose Pliers,
G84-LSKS – service kit: complete seal and fastener set for tool overhaul

G84-LSKT TOOL KIT



8 3 6 B 7 4 0
Valve Spring Installation Tool



8 3 7 B 7 4 0
Valve Sleeve Removal Tool



P 1 1 7 8
Valve Plug Extractor



744-104
Seal Guide



744-195



530-202



7 0 0 A 7 7
Air Bleeder



7 0 0 A 6 1
Piston Rod Wrench



530-201



744-194



P1444

OVERHAUL PROCEDURE

Caution:

- Maintenance and repair to be conducted only by trained personnel.
- Prior to attempting any repair or maintenance work, make sure the air is disconnected.

- Follow these instructions. Use special care handling sealing surfaces.
- Apply an O-ring lubricant (Parker® silicone lube or equivalent) on all O-ring s.
- After tool overhaul, fill with DEXRON III ATF fluid and bleed (see page 5).

AIR VALVE SUB-ASSEMBLY

Disassembly Instructions:

- Remove retaining ring (56) and muffler (55).
- Insert the valve plug extractor P1178 into the end of valve plug (54) and pull it out.
- Pull out the valve spool subassembly (86) the same way.

Note: In the unlikely event the valve sleeve (47) is irreversibly clogged, remove it as follows:

- Grab one end of spring (49) with needle-nose pliers and turn/pull to dislodge it from its groove
- After spring removal, pull out the valve sleeve (47) by using the removal tool 837B740.

Assembly Instructions: Reverse the above procedures.

Caution: Install valve sleeve (47) carefully with your fingers: gently push and wiggle it to allow O-rings to slip in. Install spring (49); use tool 836B740 to push it firmly into the groove.

HEAD CYLINDER SUB-ASSEMBLY (744-202)

Caution: Remove Pulling Heads or other attachments before attempting to disassemble.

Disassembly instructions:

- Remove screw (57) and unscrew lock ring (58) with spanner wrench 530-202.
- Drain the fluid over an oil pan; dispose according to environmental regulations.
- Remove rear stop (59) and piston (63) by pressing them out of the rear of the subassembly.
- Remove seals (60, 61, 62, 63, 65, 66, 67 & 68) carefully using a bent hook tool.

Assembly instructions:

- Inspect all components to make sure all surfaces are clean and free of burrs.
- Install O-ring and back-up ring (67 & 68) into groove of head cylinder (70).
- Thread seal guides 744-194 & 744-195 on both sides of the piston (64).
- Mount O-ring and back-up ring (65 & 66) onto the piston (64).
- Carefully push/twist piston (64) into the head cylinder (70) bore, pressing it all the way in.
- Assemble O-ring, backup ring (60 & 61) and O-ring, Back-up ring (62&63) onto rear stop (59) and carefully press it into the head cylinder.
- Thread-in lock ring (58) using spanner wrench 530-202 and secure it with screw (57); use Loctite® 242 on threads. Remove seal guides.

Swivel Assembly Instructions:

- Apply Loctite 545 on the male threads of swivel (75).
- Thread swivel (75) into head cylinder (70) and thread until hand tight.
- Using a 7/16 wrench, tighten threads by rotating one full turn from initial thread seating to secure in place – **Do not over tighten.**
- Allow Loctite to cure for 24 hours for full strength.

HANDLE SUB-ASSEMBLY (744-189)

Disassembly Instructions: Make sure that the air supply is disconnected before proceeding.

- Unscrew cap screws (19) and remove manifold (35);
- Drain the fluid completely into a pan and dispose according to environmental regulations.
- Remove gasket (22) and O-rings (21)
- Remove retaining ring (1) and the base cover (2) from the bottom of the unit.
- Remove retaining ring (3) and carefully pry handle base (4) from the bottom of the unit, using a screwdriver.
- Engage wrench 700A61 into the hex socket of the piston rod cap (26).
- Remove locknut (6) with a ½ inch (13 mm) socket, while holding with the wrench; unscrew air piston (7) by using wrench 530-201 and a 1 inch (26 mm) socket.
- Pull the air piston (7) out through the bottom of the unit with the help of the tool P1178.
- Remove power piston subassembly (84) through the top of the handle (18) using the guide tool 744-104.
- Remove the packing plug (11) with the help of wrench 530-201 and a 1 ¼ inch (32 mm) Socket.
- Note: To loosen it, hold the handle upside down in a vise, if necessary.
- Remove the O-rings (12 and 13) and back-up rings (14) with a thin, bent hook.
- Place an 1 inch (25,4 mm) rod on top of power cylinder (17) and tap it out carefully through the bottom of the unit with a mallet.

Assembly Instructions: Lubricate O-rings with Parker® silicone O-ring lube or equivalent and handle all seals with care.

- Make sure the gaskets and seals are in good condition and are placed correctly.
- Insert the power cylinder (17) with O-rings (15 & 16) into the handle (18) bore through the bottom of handle. To properly seat it, place an 1 inch (26 mm) bar against its bottom surface, and carefully tap into place with a mallet.
- Insert O-rings (13) and back-up rings (14) in packing plug (11).
- Thread packing plug in tightly against the power cylinder (17) using wrench 530-201 and a 1 ¼ inch (32 mm) socket.
- Thread seal guide tool 744-104 into the end of the power piston (25) then push into the bore of the power cylinder (17) through the top of handle (18). Tap it through the packing plug (11) with a mallet; remove the seal guide.
- Using wrench 530-201 insert air piston (7) with quad ring (9) and back-up rings (8) into the main bore of the handle (18) until it engages the threaded end of the power piston (25); tighten them together wrench 700A61.
- Thread and tighten locknut (6) onto power piston (25) with a ½" socket (13 mm) at 50 to 59 in-lbs (5,65 to 6,67 N-m).
- Insert handle base (4) with lubricated O-ring (5) into the bottom of the handle (18) and tap it into its seat.
- Place retaining ring (3), base cover (2), and retaining ring (1).
- Push the piston downwards with the help of wrench 700A61.
- Fill the handle subassembly with fluid to about 1/8 inch (3 mm) above the top of the power piston (17).
- Place new gasket & O-rings (21,22) on top of handle (18); mount the manifold (35) tightening screws (19) evenly.

TOOL CARE

This tool has been designed for optimum service with minimum care.

In order to extend the life of the tool, please follow the simple instructions given below:

- Make sure the system is filled properly with fluid and is free of air (see fill and bleed instructions)
- Do not use any substitutes for DEXRON III ATF or spare components
- Use only clean air; dirt and moisture will cause damage to the pneumatic system.
- Inspect for air and fluid leaks routinely. Minor fluid loss over time is normal, but increased fluid or air loss indicates seal damage. Make sure that all fittings are properly tightened and secured.
- Do not operate with hoses unprotected or with a damaged hose wrap.
- Perform regular maintenance.

TROUBLESHOOTING GUIDE

PROBLEM	POSSIBLE REASONS / SOLUTIONS
Piston does not move after depressing Trigger	- No air supply is connected: Connect to a clean, filtered air source at 90 to 110 psi (6,2 to 7,6 bar).
	- Faulty trigger: Remove and replace trigger assembly.
	- Broken power piston: Service the Handle Subassembly per page 7.
Short stroke or low pull force	- Significant fluid loss: Bleed the system per page 5. If performance doesn't improve, or excessive leakage continues, see below.
Head Cylinder Fluid leakage	- Leaks around the plugs (69) or fittings indicate that they are not tightened to seal properly: Tighten until no more leaks are observed.
	- Leaks at the front or back of head cylinder (70) indicate worn or damaged seals:
	Service head cylinder per page 7.
Air leakage at the valve	- Broken or dislodged spring (49).
	- Worn or damaged valve spool seals: Disassemble and service air valve per Air Sub-Assembly Overhaul Instructions.
Head piston (64) is slow or seizes	- Piston or seal damage: Service head cylinder per page 7.
	- Oil bypassing due to power piston (25) displacement Of its seat in subassembly (84): Service Handle Subassembly per page 7.
	- Clogged muffler (55) or air filter (51): Clean thoroughly with solvent and back-blow with compressed air.
	- Lock ring (item 58) is not secured due to loose cap screw (57): Tighten lock-ring, and then secure it by tightening cap screw. Use Loctite® removable thread locker to secure it.
Head Piston (64) does not return fully forward even after system bleeding	- Pressure relief valve (85) malfunction: Remove valve then O-ring (42) from the manifold (35). Clean and dry thoroughly components. Replace O-Ring (use Parker® silicone O-ring lube or equivalent). Re-assemble valve; make sure the O-ring (42) is seated concentrically inside of the valve cavity before installing the Ball-seat (41) into the manifold (35).
	- Compression spring (31) is damaged or broken: Remove handle manifold (35) and replace the damaged spring. Re-assemble, fill and bleed per page 5.

Cherry® is well known for the quality of our tools and our outstanding customer support.

If the tool does not perform at the expected performance please contact our representatives.

LOCTITE® is a registered trademark of Henkel Corporation

DEXRON® is a registered trademark of GM Corporation.

PARKER® is a trademark of Parker Hannifin Corporation

PART LIST FOR THE G84-LS SPLIT RIVETER (744-190)

ITEM NO.	PART NO	DESCRIPTION	QTY	
744-189 Sub-Assembly, Handle			1	
1	P884	Ring, Retaining	1	
2	740B5	Cover, Base	1	
3	P886	Ring, Retaining	1	
4	740C4	Base, Handle	1	
5	P890	O-Ring	1	
6	P1392	Nut, Conelok	1	
7	744-094	Piston, Air	1	
8	P909	Ring, Back-Up	2	
9	P887	Ring, Quad	1	
10	744-095	Washer, Air Piston	1	
11	744-165	Plug, Packing	1	
12	P889	O-Ring	1	
13	P1405**	O-Ring	2	
14	P1410	Ring, Back-Up	2	
15	P892**	O-Ring	1	
16	P833**	O-Ring	1	
17	744-161	Cylinder, Power	1	
18	743A11	Handle	1	
19	P73	Cap Screw, Soc. Head	4	
20	530A113	Cap Screw, Button Head.	1	
21	P832**	O-Ring	2	
22	744-171	Gasket, Manifold	1	
84	744-122	Sub-Assembly, Power Piston And Rod	1	
	23	744-164*	Rod, Power Piston	1
	24	740A12*	Stop, Piston	1
	25	744-163*	Piston, Power	1
	26	744-087*	Cap, Piston Rod	1
27	P1406	O-Ring	1	
28	P213	Ring, Back-Up	1	
29	744-160	Piston, Return	1	
30	P104	O-Ring	1	
31	P1414	Spring, Compression	1	
32	744-175	Cylinder, Return	1	
33	P573	Screw, Button Hd. Cap	2	
34	P572	Stat-O-Seal	2	
35	744-188	Manifold, Handle	1*	
85	700-214	Sub-Assembly, Relief Valve	1	
	36	700-218	Seat, Spring	1
	37	P383	O-Ring	1
	38	P1366	Spring	1
	39	700-217	Piston, Valve	1
	40	P688	Ball	1
	41	700-215	Seat, Ball	1
	42	P111	O-Ring	1
43	530A34	Swivel	1	
44	P195	O-Ring	2	
45	530A35	Swivel Bolt	1	

ITEM NO.	PART NO.		DESCRIPTION	QTY
	46	P268	O-Ring	4
	47	740B14	Sleeve, Valve	1
	48	P891**	O-Ring	3
	49	740A18	Spring	1
	86	740A15	Sub-Assembly, Valve Spool	1
	50	740B15-1*	Spool, Valve	1
	51	700A18*	Filter	1
	52	700A69*	Screw, Metering	1
	53	P848	O-Ring	2
	54	740B16	Plug, Valve	1
	55	740A17	Muffler	1
	56	P321	Ring, Retaining	1
744-202 Sub-Assembly, Head Cylinder				1
	57	P85	Screw, Soc. Hd. Cap	2
	58	744-144	Lock, Ring, Power	1
	59	744-142	Stop, Rear	1
	60	P1419	Ring, Back-Up	1
	61	P1420	O-Ring	1
	62	P1411	Ring, Back-up	1
	63	P1407	O-Ring	1
	64	744-140	Piston, Head	1
	65	P1412	Ring, Back-up	1
	66	P1409**	O-Ring	1
	67	P1408**	O-Ring	1
	68	P209**	Ring, Back-up	1
	69	P698	Pipe, Level Seal	2
	70	744-168	Cylinder, Head	1
	71	744-145	Stop, Pulling Head	1
703A33 Sub-Assembly, Trigger				1
	72	530A38	Trigger	1
	73	703A32	Sleeve, Trigger	1
	74	P223	O-Ring	1
75	744-150	Swivel, High Pressure		2
76	744-185	Trigger, Manifold		1
77	P1415	Assembly, High Pressure Hose		2
78	744-186	Air Tubing		1
79	P1453	Barbed Air Fitting		2
80	P1452	Tubing Clamp		2
81	744-193	Cable Wrap		1
82	744-503***	Fitting, Pin Deflector (sold separately)		1
83	530A16***	Pin Deflector (sold separately)		1

* Only within subassembly; component not sold separately.

** No Substitutions

*** Not provided in standard configuration - to be purchased as needed.

G84-LS CROSS SECTIONAL VIEW

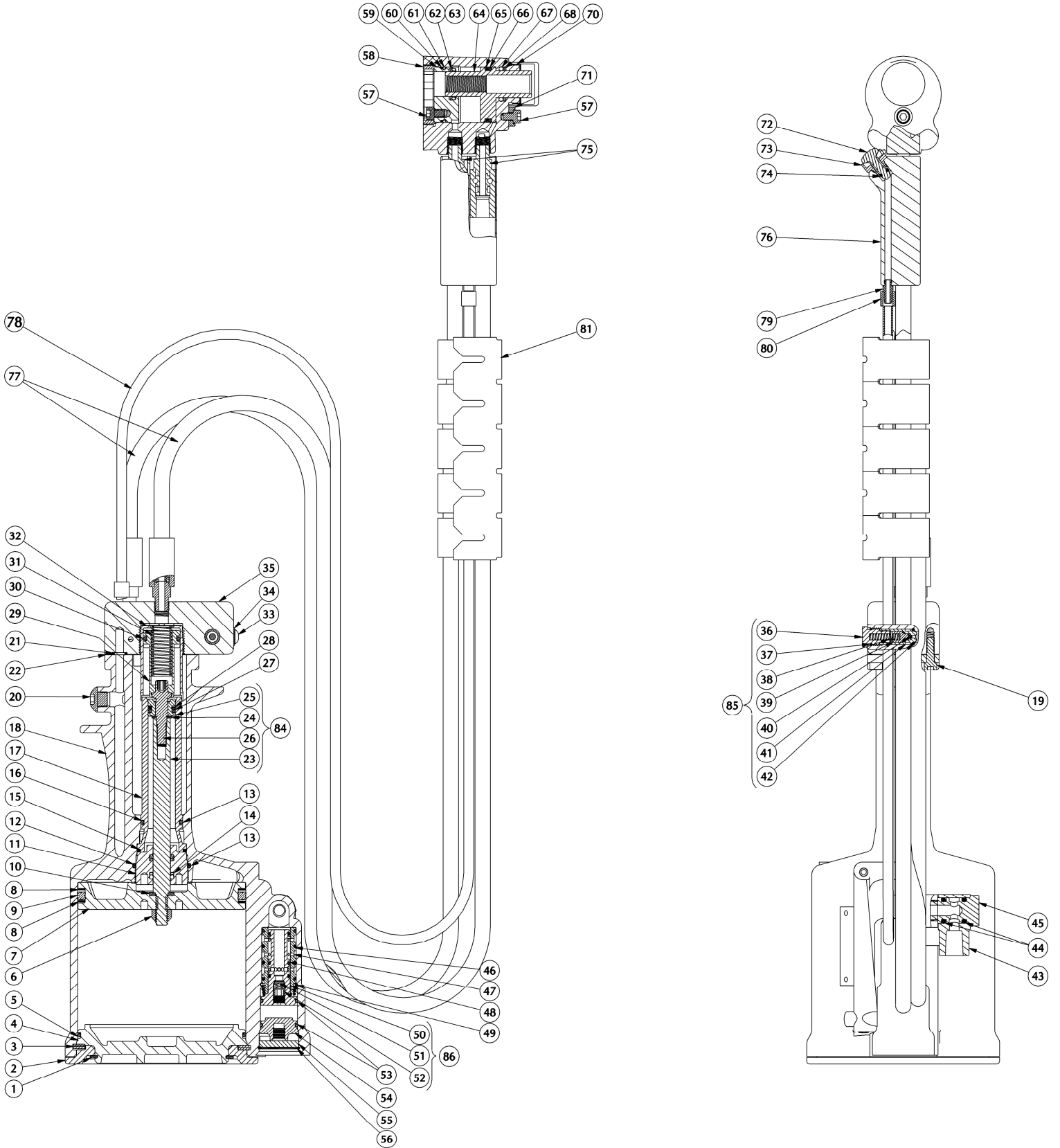

**G84-LS
EXPLODED
VIEW**

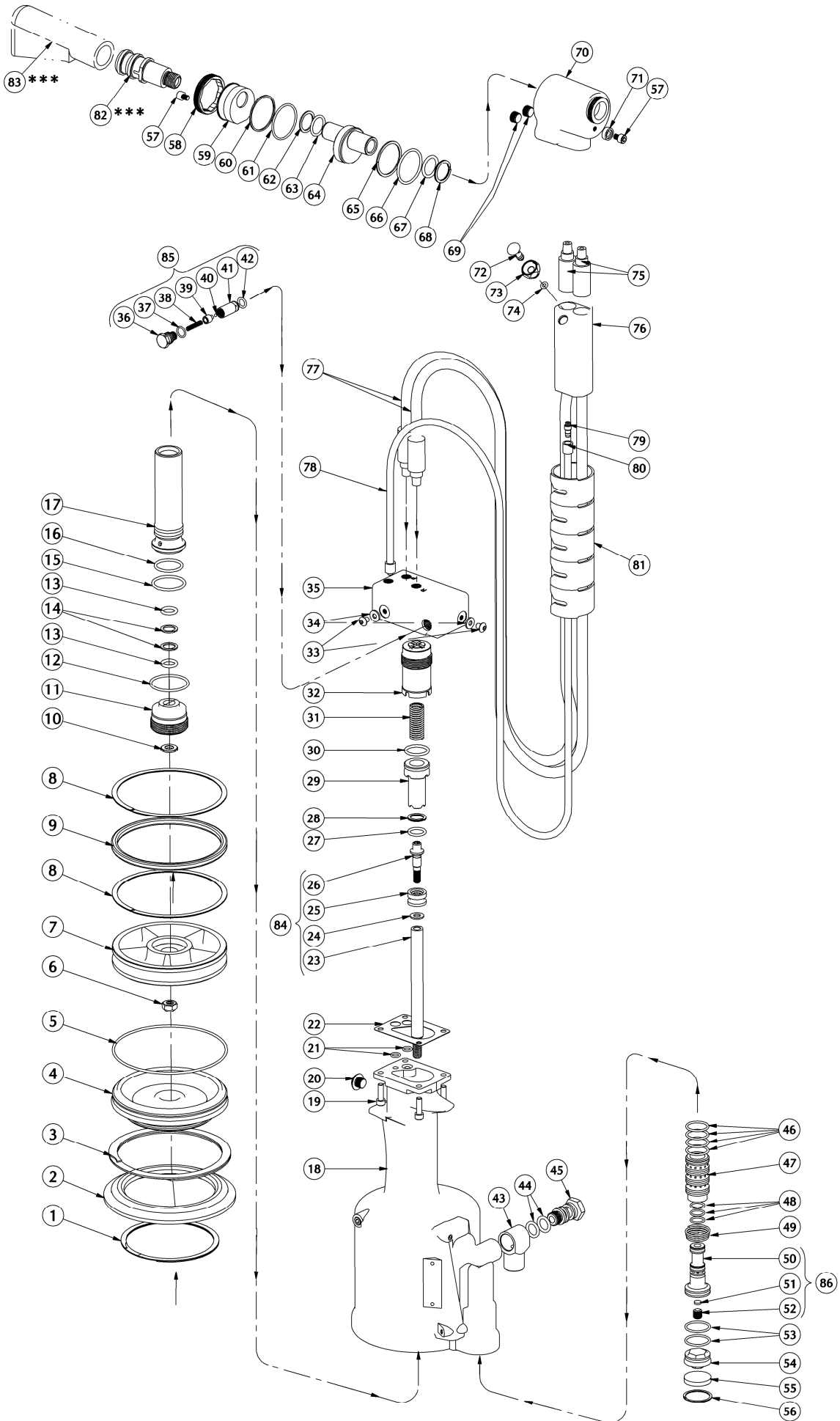

Declaration of Conformity

We, Cherry Aerospace, 1224 E. Warner Ave., Santa Ana, CA 92705

declare under our sole responsibility that the product

type G84-LS

Serial No. _____

to which this declaration relates is in conformity with the following standards

EN ISO 12100- parts 1 &2

ISO 8662 part 1

I S O 3 7 4 4

following the provisions of the Machine Directive 2006/42/EC

Santa Ana, CA - date of issue _____

Original certification and signature on file

WARRANTY

Seller warrants the goods conform to applicable specifications and drawings and will be manufactured and inspected according to generally accepted practices of companies manufacturing industrial or aerospace fasteners. In the event of any breach of the foregoing warranty, Buyer's sole remedy shall be to return defective goods (after receiving authorization from Seller) for replacement or refund of the purchase price, at the Seller's option. Seller agrees to any freight costs in connection with the return of any defective goods, but any costs relating to removal of the defective or nonconforming goods or installation of replacement goods shall be Buyer's responsibility. SELLER'S WARRANTY DOES NOT APPLY WHEN ANY PHYSICAL OR CHEMICAL CHANGE IN THE FORM OF THE PRODUCT IS MADE BY BUYER. THE FOREGOING EXPRESS WARRANTY AND REMEDY ARE EXCLUSIVE AND ARE IN LIEU OF ALL OTHER WARRANTIES AND REMEDIES; ANY IMPLIED WARRANTY AS TO QUALITY, FITNESS FOR PURPOSE, OR MERCHANTABILITY IS HEREBY SPECIFICALLY DISCLAIMED AND EXCLUDED BY SELLER. THIS WARRANTY IS VOID IF SELLER IS NOT NOTIFIED IN WRITING OF ANY REJECTION OF THE GOODS WITHIN ONE (1) YEAR AFTER INITIAL USE BY BUYER OF ANY POWER RIVETER OR NINETY (90) DAYS AFTER INITIAL USE OF ANY OTHER PRODUCT.

Seller shall not be liable under any circumstances for incidental, special or consequential damages arising in whole or in part from any breach by Seller, AND SUCH INCIDENTAL, SPECIAL, OR CONSEQUENTIAL DAMAGES ARE HEREBY EXPRESSLY EXCLUDED.

For more information please contact our Technical Services Department at Tel. 714-850-6022



CHERRY®
AEROSPACE
SPS Fastener Division, a PCC Company

1224 East Warner Ave,
Santa Ana, CA 92705
Tel: 1-714-545-5511
Fax: 1-714-850-6093
www.cherryaerospace.com

© 2007 Cherry Aerospace

Supplier's Federal Identification Code: 11815

TM-G84-LS
Rev.: F
DCR# 09-1232
Date: 12/1/09