

FlexAlert Multifunction Annunciator

Installation Manual

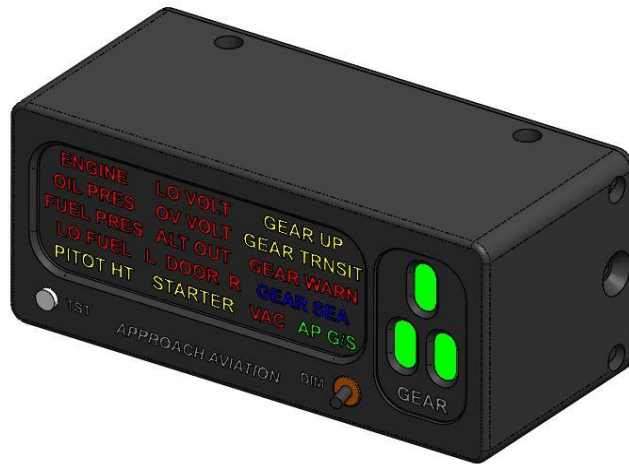

SalesApproach, Inc. - This copyrighted work and all information are the property of SalesApproach, Inc. and may not, in whole or in part, be used, duplicated, or disclosed for any purpose other than for installation of the FlexAlert Annunciator without prior written permission of SalesApproach, Inc. All Rights Reserved. Copyright 2017 SalesApproach, Inc.

SalesApproach, Inc.
 30 Sheffield Terrace, Marlborough, MA 01752
 978 314-4626

DOCUMENT MAINTENANCE

REVISION HISTORY				
REVISION	PRN/CO NO.	DATE	BY	DESCRIPTION of CHANGE
Original		May 10, 2017	Jeff Simon	Original

1.	Overview	4
2.	Components	4
3.	Features & Operation	5
3.1.	No Active Annunciations.....	5
3.2.	Test Mode	5
3.3.	Gear Mode	5
3.3.1.	Gear Down and Locked – Tricycle Gear.....	6
3.3.2.	Gear Up.....	6
3.3.3.	Gear Transit	6
3.3.4.	Gear Warning	6
3.3.5.	Gear Up Indication for Water Operations (Seaplane)	6
3.4.	Engine Warning	6
3.5.	Oil Pressure Warning.....	6
3.6.	Fuel Pressure Warning.....	6
3.7.	Low Fuel Warning	7
3.8.	Pitot Heat	7
3.9.	Low Voltage Warning.....	7
3.10.	Over Voltage Warning.....	7
3.11.	Alternator Warning.....	7
3.12.	Door Warning Indications	7
3.13.	Starter Engaged.....	7
3.14.	Vacuum Warning.....	7
3.15.	A/P Glideslope Capture	7
4.	Installation.....	8
4.1.	Mounting	8
4.2.	Electrical Connections	9
4.3.	Power	9
4.4.	Interfaces	9
4.5.	Switches.....	10
4.6.	Configuration Settings.....	10
5.0.	Installation Verification Testing	12
	APPENDIX A.....	13

1. Overview

The FlexAlert Multifunction Annunciator is an all-in-one multi-annunciation unit that can be installed in 14 CFR Part 23 aircraft as a minor alteration for supplementary annunciation purposes, consolidating the visual display of a variety of existing warning and condition annunciators for items such as landing gear, engine warnings, vacuum warnings, etc.

The annunciator is designed to be sunlight readable, dimmable and has an integral test feature. It utilizes LED technology, can be wired for existing lamps that have either switched ground wires or switched power wires (pull-up or pull-down operations) and can operate on 14V or 28V aircraft systems with no modifications.

Installation of the FlexAlert Multifunction Annunciator is approved as a minor alteration under the FAA's Non-Required Safety Enhancing Equipment (NORSEE) standards. The annunciator does not replace flight critical, pre-existing annunciation lights. Rather, it enhances safety by replicating and consolidating annunciations in a single location within the pilot's field of view.

If the FlexAlert Multifunction Annunciator is installed as a replacement, rather than a supplement, to existing flight critical annunciations (such as landing gear), it is the responsibility of the installer to ensure the installation meets all regulatory approvals.

2. Components

Annunciator Kit P/N APAV-ANU100 includes the following components:

Component	Part Number
Annunciator Unit	APAV-ANU100-ANU
Cover Plate for Fixed Gear Aircraft	APAV-ANU100-FGC
Installation Kit (brackets, screws, connectors, etc.)	APAV-ANU100-INST
Installation Manual	APAV-ANU100-IM
Operations Manual	APAV-ANU100-OM

3. Features & Operation

3.1. No Active Annunciations

When no annunciations are active, the annunciator display face is dark. The unit face has markings indicating where the gear annunciations are located, as well as labels for the brightness and test controls.

3.2. Test Mode

The test mode is initiated by the pilot and is designed to illuminate all annunciations that the annunciator is configured to display. Configuration is done during installation.



Test Mode

Test mode utilizes a discrete test power input on the unit. The indications are being tested, not the warning sensor. Test mode works in both Bright and Dim settings. The unit has an internal hardware configuration which allows the unit to remain in test mode (when not installed in an aircraft) for demonstration purposes.

3.3. Gear Mode

The Annunciator is designed to replicate the existing, primary gear lights for the aircraft and will work with a wide range of retractable landing gear annunciation configurations, including the following:

- Aircraft with one gear light, or individual gear lights
- Tricycle Landing Gear with nose gear, left main gear and right main gear retractable
- Tricycle Landing Gear with only retractable nose gear, or only retractable left and right main gear
- Aircraft with Gear Warning alerts (triggered by airspeed, altitude, throttle position, etc.)
- Aircraft with indications of unsafe gear or gear in-transition
- Aircraft with indications of gear up (stowed) as a normal condition
- Aircraft with indications of gear up (stowed) as a warning condition
- Seaplane pilots requiring a BLUE indication of gear up for water operations

Each of the three gear lights are controlled through independent inputs to the annunciator. There are three individual gear-down annunciations (displayed in GREEN) identifying the nose gear, left main gear and right main gear. Depending on the configuration of the aircraft, the installer can tie into the existing light(s) configuring the unit for display of each individual gear “down and locked” or all three annunciations can be wired in parallel to match aircraft with a single gear “down and locked” light.

The following are sample gear modes. Other configurations can also be set by the installer to match the configuration of the primary gear annunciations for the aircraft.

3.3.1. Gear Down and Locked – Tricycle Gear



3.3.2. Gear Up

There are 2 inputs for “GEAR UP”. One is to display “GEAR UP” in AMBER, indicating a normal condition of gear-up cruise configuration. The unit can also be configured to display “GEAR UP” in RED, indicating a warning condition.

ONLY ONE of the two options may be activated at a time. Do not wire both RED and AMBER “GEAR UP” inputs in parallel to be activated simultaneously.

3.3.3. Gear Transit

If the aircraft has a primary gear annunciation for gear in transit, the installer can tie into the existing light, configuring the unit to display “GEAR TRNSIT” (displayed in AMBER).

3.3.4. Gear Warning

If the aircraft has a primary gear annunciation for gear warning, the installer can tie into the existing light, configuring the unit to display “GEAR WARN” (displayed in RED).

3.3.5. Gear Up Indication for Water Operations (Seaplane)

If the aircraft has a primary gear annunciation for gear up for water operations (seaplane), the installer can tie into the existing light, configuring the unit to display “GEAR SEA” (displayed in BLUE).

3.4. Engine Warning

If the aircraft has a primary annunciation for engine warning, such as from an engine monitor, the installer can tie into the existing light, configuring the unit to display “ENGINE” (displayed in RED).

3.5. Oil Pressure Warning

If the aircraft has a primary annunciation for oil pressure warning, the installer can tie into the existing light, configuring the unit to display “OIL PRES” (displayed in RED).

3.6. Fuel Pressure Warning

If the aircraft has a primary annunciation for fuel pressure warning, the installer can tie into the existing light, configuring the unit to display “FUEL PRES” (displayed in RED).

3.7. Low Fuel Warning

If the aircraft has a primary annunciation for low fuel warning, the installer can tie into the existing light, configuring the unit to display “LO FUEL” (displayed in RED).

3.8. Pitot Heat

If the aircraft has a primary annunciation for pilot heat, the installer can tie into the existing light, configuring the unit to display “PITOT HT” (displayed in AMBER).

3.9. Low Voltage Warning

If the aircraft has a primary annunciation for low voltage warning, the installer can tie into the existing light, configuring the unit to display “LO VOLT” (displayed in RED).

3.10. Over Voltage Warning

If the aircraft has a primary annunciation for over voltage warning, the installer can tie into the existing light, configuring the unit to display “OV VOLT” (displayed in RED).

3.11. Alternator Warning

If the aircraft has a primary annunciation for alternator warning, the installer can tie into the existing light, configuring the unit to display “ALT OUT” (displayed in RED).

3.12. Door Warning Indications

There are three individual door warning annunciations (displayed in RED): L/DOOR/R. Depending on the configuration of the aircraft, the installer can tie into the existing door warning light(s) configuring the unit for display of a general door warning (“DOOR”), left door warning (“L DOOR”) or right/rear door warning (“DOOR R”). The installer selects which of the individual door annunciations to wire, individually or in parallel to match the existing door warning lights in the aircraft.

3.13. Starter Engaged

If the aircraft has a primary annunciation for starter engaged, the installer can tie into the existing light, configuring the unit to display “STARTER” (displayed in AMBER).

3.14. Vacuum Warning

If the aircraft has a primary annunciation for vacuum warning, the installer can tie into the existing light, configuring the unit to display “VAC” (displayed in RED).

3.15. A/P Glideslope Capture

If the aircraft has a primary annunciation for glideslope capture, the installer can tie into the existing light, configuring the unit to display “AP G/S” (displayed in GREEN).

4. Installation

4.1. Mounting

There are eight mounting holes built into the unit: two on the top, two on the bottom and two on each side. Brackets are included with the unit, allowing the installer to select **EITHER** a side mounting **OR** a top/bottom mounting style. It is designed to be flush mounted through the instrument panel with the unit behind the panel. Attachment to the panel is via MS35214 #6 brass instrument screws or similar, mating to a corresponding #6 locknut.

A mounting cut-out template is provided with the installation kit (Ref Appendix A – Figure 1).

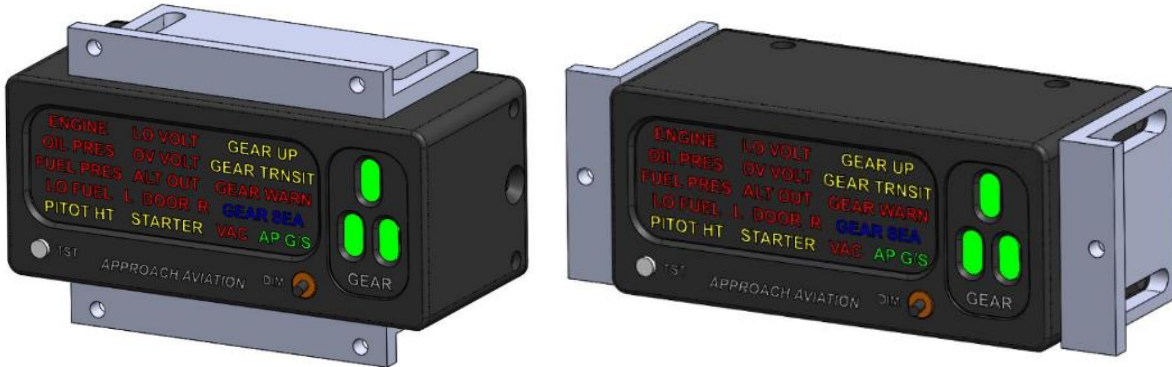

Unit shown with both top/bottom mounting brackets AND left/right mounting brackets (installer chooses top/bottom OR left/right mounting style)



PANEL CUTOUT FOR ANNUNCIATOR MOUNTING

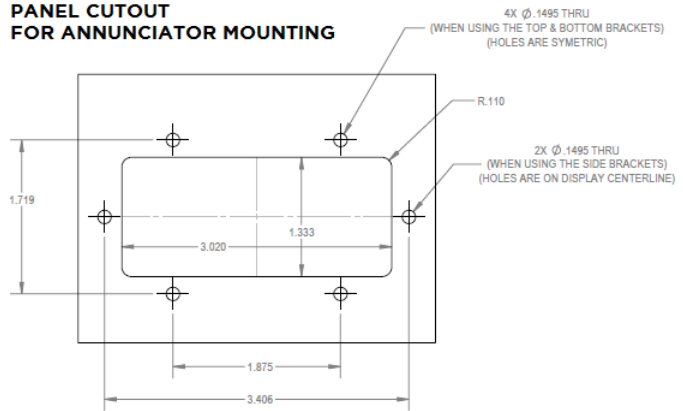

Mounting to the aircraft instrument panel must be in accordance with AC 43.13-2B. The unit is designed to exceed the structural mounting requirements detailed in AC 43.13-2B: 3.0g (up), 1.5g (side), 9.0g (forward), 6.6g (down). **It is the responsibility of the installer to ensure that the sub-structure (panel) that the annunciator is mounted to meets the structural requirements for safe installation and operation.**

4.2. Electrical Connections

The installer must take the following into consideration before installation:

- The installer is responsible for supplying wires, cables, connectors and circuit breakers.
- All wiring must be in accordance with industry-accepted methods, techniques and practices.
- Care must be taken not to damage or affect existing aircraft annunciators, lamps or signal sources.
- Use of any wire or cable not meeting specification voids all warranties.
- All wires should be 22 AWG. Use M22759 or equivalent wire.

4.3. Power

The annunciator is designed with power and ground on Pins 1 (Power) & 2 (Ground) using an external 0.75A fuse or pull-type circuit breaker. The annunciator can operate on 14V or 28V aircraft systems with no modifications.

4.4. Interfaces

The FlexAlert Multifunction Annunciator uses a proprietary “single wire sense” technology. Each individual annunciation requires only a single wire to be run to the switched-side of the sensor/lamp that is outputting the desired signal for display.

The annunciator will automatically sense whether the input signal is a switched ground or switched power source and adapt accordingly.

Discrete inputs for annunciations are connected via a female DB26 connector located at the rear of the unit. Pinout information is as follows in Table 4-1.

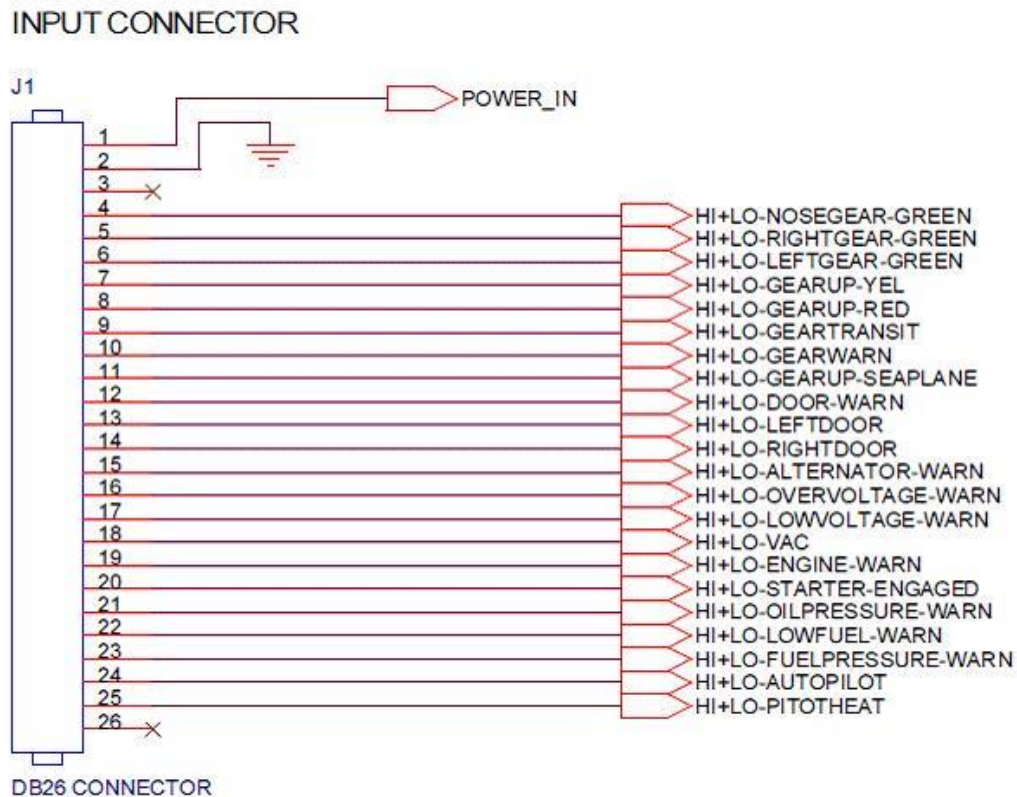

TABLE 4-1

4.5. Switches

The face of the annunciator includes buttons for test and brightness.

DIM – Toggle switch alternating between normal (day) and dim (night) settings

TST – Pushbutton momentary switch to activate Test Mode, annunciating all configured annunciations

4.6. Configuration Settings

The annunciator is equipped with configuration switches for each annunciation, accessible through the rear of the unit. Each annunciation that has been wired to a source signal on the aircraft must have the corresponding switch set to “ON”. All unused annunciations must be set to “OFF”. Setting the configuration switches properly ensures that ONLY configured annunciations will illuminate when the unit is placed into test mode. See Table 4-2 for switch identification.

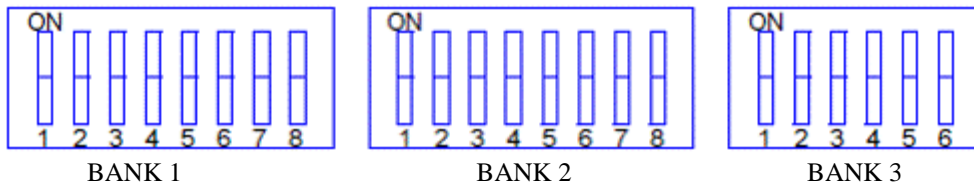

CONFIGURATION SWITCH LOCATIONS

BANK	SWITCH	FUNCTION
1	1	NOSE GEAR DOWN
1	2	RIGHT MAIN GEAR DOWN
1	3	LEFT MAIN GEAR DOWN
1	4	GEAR IN SEA MODE
1	5	GEAR UP (AMBER)
1	6	GEAR WARNING
1	7	VACUUM
1	8	GEAR TRANSIT
2	1	PITOT HEAT
2	2	GEAR UP (RED)
2	3	DOOR INDICATION
2	4	L (DOOR INDICATION)
2	5	R (DOOR INDICATION)
2	6	ALTERNATOR
2	7	OVER VOLTAGE
2	8	LOW VOLTAGE
3	1	ENGINE
3	2	STARTER
3	3	OIL PRESSURE
3	4	LOW FUEL
3	5	FUEL PRESSURE
3	6	AUTOPILOT GLIDESLOPE CAPTURE

TABLE 4-2

CONFIGURATION SWITCH SETTINGS

4.7. Cover Plate for Fixed-Gear Aircraft

An optional fixed-gear cover plate is included for fixed-gear aircraft installations. The cover is applied in the designed recess in the face of the unit to cover the location of the 3 gear lights.

5.0. Installation Verification Testing

Following installation, the installer must verify the proper functioning of each annunciation installed including the following:

- The annunciation illuminates when active and is off when not active
- The original (pre-existing) annunciator, if available, illuminates when active and is off when not active
- The annunciation illuminates when the unit is placed into test mode
- The **original** (pre-existing) annunciator, if available, does **not** illuminate when the FlexAlert annunciator is placed into test mode.

6.0. Specifications

Operating Voltage: 10.5V (min), 30V (max)

Total Unit Maximum Current Draw on power input:

0.5A at 10V

0.4A at 14V

0.2A at 28V

Current Protection:

0.75A External Fuse Required During Installation

1.0A Internal Fuse Protection

Sensing Voltage for Discrete Annunciation Inputs:

High Input:

Active: $4\text{VDC} < V_{in} \leq 33\text{VDC}$

Inactive: $V_{in} < 2\text{VDC}$

Low Input:

Active: $V_{in} < 1\text{VDC}$

Inactive: $4\text{VDC} < V_{in} \leq 33\text{VDC}$

Sink Current (per discrete input):

.7ma max @28V

.4ma max @14V

Operating Temperature: -20C (min), 60C (max)

Altitude: Sea Level (min) to 25,000' (max)

APPENDIX A

Installation Template

REV.	DESCRIPTION	DATE	DRAWN
A	INITIAL RELEASE	3/10/2017	CAP

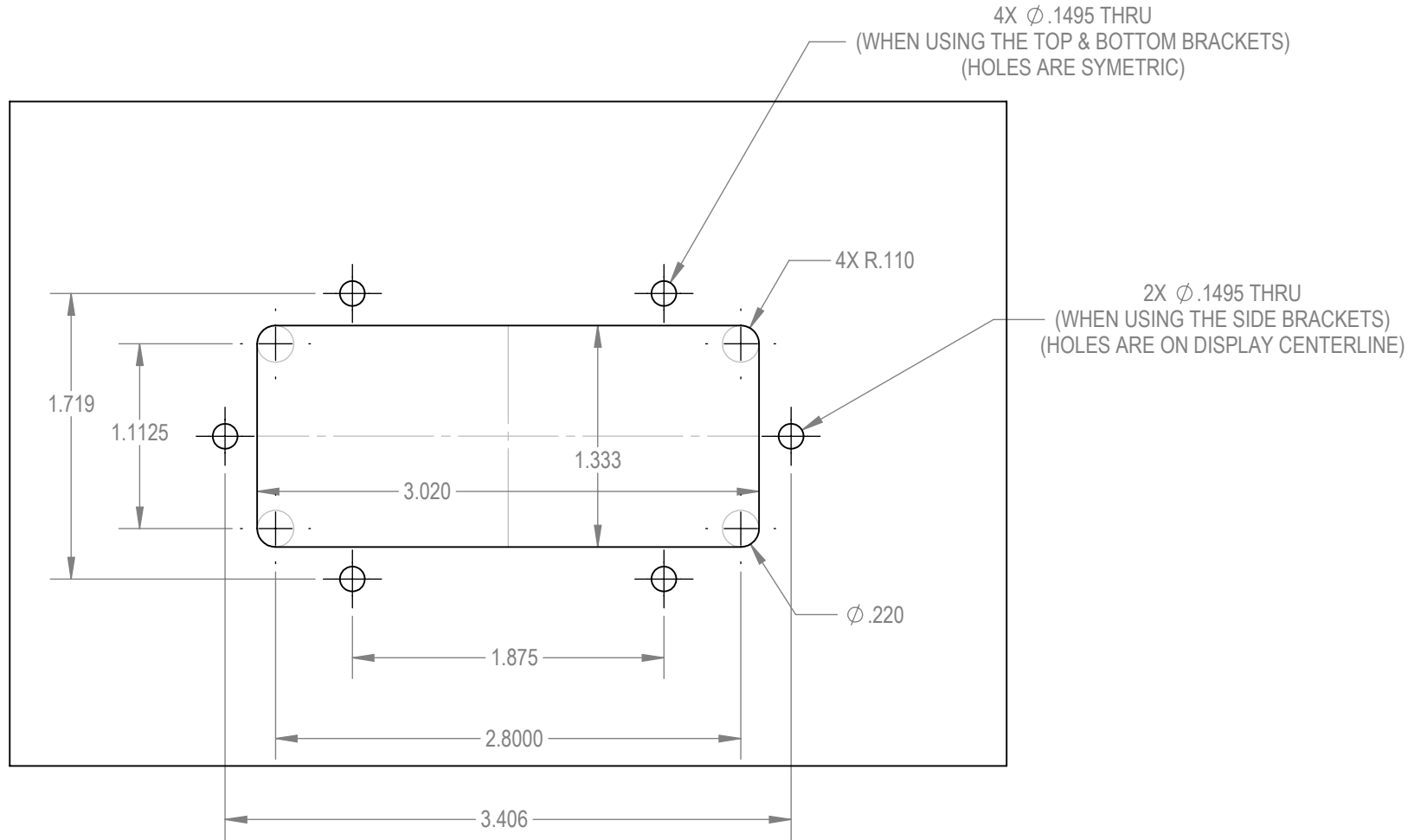

Approach Aviation

HOLES ARE SYMMETRICAL

<small>UNLESS OTHERWISE SPECIFIED: UNITS ARE IN INCHES AND TOLERANCES ON DIMENSIONS ARE IN INCHES</small> <small>.X = \pm.03 .XX = \pm.01 .XXX = \pm.005 DEG. = \pm1° X/X = \pm 1/16</small>	DRAWN:	CAP	PROJECT:	ANNUNCIATOR	
	DATE:	7/19/2017	TITLE:	ANNUNCIATOR DASH CUTOUT	
	SHEET:	1	SCALE:	1:1	
	SIZE:	A	QUANTITY:		
	MATERIAL:	Material <not specified>	PART #	Dash-Model	A