



July 20, 2010

MK182-55-01B

**TITLE**

HORIZONTAL STABILIZER ABRASION BOOT INSTALLATION

**EFFECTIVITY**

Model	Serial Numbers
182S	18280001 thru 18280944
182T	18280945 and On
T182T	T18208001 and On

**DESCRIPTION**

This modification kit provides parts and instructions for installation of abrasion boots on the leading edge of the horizontal stabilizer.

**APPROVAL**

FAA approval has been obtained on technical data in this publication that affects airplane type design.

**REFERENCE**

SNL06-7

**WEIGHT AND BALANCE INFORMATION**

<b>MODEL</b>	182/T182
<b>WEIGHT CHANGE</b>	+1.2 pounds
<b>ARM</b>	209.0 inches
<b>RESULTANT MOMENT</b>	244 inch-pounds
<b>MOMENT/1000</b>	0.24 inch-pounds

Original Issue: April 16, 1999

Page 1 of 6

To obtain satisfactory results, procedures specified in this publication must be accomplished in accordance with accepted methods and prevailing government regulations. Cessna Aircraft Company cannot be responsible for the quality of work performed in accomplishing the requirements of this publication.

Cessna Aircraft Company, Customer Service, P.O. Box 7706, Wichita, Kansas 67277, U.S.A. (316) 517-5800, Facsimile (316) 517-7271  
www.cessnasupport.com

## MATERIAL INFORMATION

**NOTE:** The modification kit listed below will be necessary:

NEW P/N	QUANTITY	DESCRIPTION	OLD P/N	DISPOSITION
<b>MK182-55-01B</b>	1	<b>Kit</b> , consisting of the following parts:		
0732042-3	1	Boot, Left Stabilizer Abrasion	1232040-5 (if installed)	Discard (if installed)
0732042-4	1	Boot, Right Stabilizer Abrasion	1232040-5 (if installed)	Discard (if installed)
	1	Instructions		

In addition to the above kit, the materials that follow, or equivalent, may be necessary:

NAME	NUMBER	MANUFACTURER	USE
Alodine 1132 Marker	U074093	Cessna Aircraft Company Cessna Parts Distribution 5800 East Pawnee PO Box 1521 Wichita, KS 67218	To apply to bare metal
MPK		Eastman Chemical Products Wilcox Drive and Lincoln Street PO Box 1521 Kingsport, TN	To remove the old abrasion boots
Masking Tape		Commercially Available	To protect boots during application of paint primer
K000912	Corrosion Resistant Primer (1.5 gal kit)	Cessna Aircraft Company Cessna Parts Distribution 5800 East Pawnee PO Box 1521 Wichita, KS 67218	To apply to bare area to be covered by boots
Scotch Brite Pad (or 320-grit or finer equivalent abrasive)		Commercially Available	To abrade surface of horizontal stabilizer

## ACCOMPLISHMENT INSTRUCTIONS

**WARNING: ELECTRICALLY GROUND THE AIRPLANE TO PREVENT STATIC SPARKS WHICH CAN IGNITE SOLVENT VAPORS. KEEP AIRPLANE GROUNDED THROUGHOUT BOOT INSTALLATION.**

1. Prepare the airplane for maintenance.
  - A. Make sure that all switches are in the OFF/NORM position.
  - B. Disconnect electrical power from the airplane.
    - (1) Disconnect the airplane battery.
    - (2) Disconnect external electrical power.

- C. Attach maintenance warning tags to the battery and external power receptacle that have "**DO NOT CONNECT ELECTRICAL POWER - MAINTENANCE IN PROGRESS**" written on them.
2. Make sure that the air temperature in the work area is no less than 50 °F (10 °C).
- NOTE:** For those airplanes that have complied with Cessna Modification Kit MK182-55-01 Original Issue or MK182-55-01 Revision A, go to Step 3.
- NOTE:** For those airplanes that have not complied with Cessna Modification Kit MK182-55-01 Original Issue or MK182-55-01 Revision A, go to Step 4.
3. Remove the 1232040-5 Left and Right Stabilizer Abrasion Boots as follows:
- A. Carefully loosen one end of the 1232040-5 Left and Right Stabilizer Abrasion Boots.
- B. Carefully pull the 1232040-5 Left and Right Stabilizer Abrasion Boots off of the horizontal stabilizer.
- C. With Methyl n-Propyl Ketone (MPK) and a Scotch Brite pad (or equivalent), remove all signs of the 1232040-5 Left and Right Stabilizer Abrasion Boots (all of the neoprene rubber and the adhesive that bonded it to the surface) from the surface of the horizontal stabilizer. (Refer to the Model 182/T182 Series 1997 and On Maintenance Manual, Chapter 20, General Solvents/Cleaners - Maintenance Practices.)
- D. If the leading edge of the stabilizer has no paint applied, prepare the surface as follows:
- (1) Clean and prepare the surface where you will apply Alodine and corrosion resistant primer. (Refer to the Model 182/T182 Series 1997 and On Maintenance Manual, Chapter 12, Airplane Exterior - Cleaning/Painting.)
- (2) Apply masking tape as necessary around the areas of the horizontal leading edge that are not painted.
- (3) Apply Alodine to the area.
- (4) Apply a coating of corrosion resistant primer. (Refer to the Model 182/T182 Series 1997 and On Maintenance Manual, Chapter 12, Airplane Exterior - Cleaning/Painting.)
- (5) Allow the corrosion resistant primer to cure.
- (6) Remove the masking tape.
4. Install the 0732042-3 Left Stabilizer Abrasion Boot and the 0732042-4 Right Stabilizer Abrasion Boot as follows:
- A. (Refer to Figure 1, Detail D.) Put masking tape on the centerline along the full length of the 0732042-3 Left Stabilizer Abrasion Boot and the 0732042-4 Right Stabilizer Abrasion Boot.
- B. (Refer to Figure 1, View A-A.) With masking tape, temporarily attach the 0732042-3 Left Stabilizer Abrasion Boot and the 0732042-4 Right Stabilizer Abrasion Boot to the horizontal stabilizer leading edge in the correct installation position. Make sure that the centerline of the boot aligns with the most forward edge of the horizontal stabilizer.
- C. (Refer to Figure 1, Detail A, Detail B, and Detail C.) Adjust the position of the 0732042-3 Left Stabilizer Abrasion Boot and the 0732042-4 Right Stabilizer Abrasion Boot as necessary to give a clearance of no less than 0.10 inch between the inboard edge of the boots and the 0732614 Stabilizer Leading Edge Fairings and a clearance of no less than 0.10 inch between the outboard edge of the boots and the 1232604 Stabilizer Tips.
- NOTE:** You can remove material from the 0732042-3 Left Stabilizer Abrasion Boot and the 0732042-4 Right Stabilizer Abrasion Boot as necessary to make the clearance of no less than 0.10 inch between the inboard edge of the boots and the 0732614 Stabilizer Leading Edge Fairings and the clearance of no less than 0.10 inch between the outboard edge of the boots and the 1232604 Stabilizer Tips.
- D. Put masking tape on the horizontal stabilizer to show the position of the edges of the 0732042-3 Left Stabilizer Abrasion Boot and the 0732042-4 Right Stabilizer Abrasion Boot.

- E. Remove the 0732042-3 Left Stabilizer Abrasion Boot and the 0732042-4 Right Stabilizer Abrasion Boot from the horizontal stabilizer.
  - F. As necessary, use a Scotch Brite Pad to lightly abrade the surface of the installation area and then clean the surface with a lint-free cloth. (Refer to the Model 182/T182 Series 1997 and On Maintenance Manual, Chapter 20, General Solvents/Cleaners - Maintenance Practices.)
  - G. Remove the backing from the 0732042-3 Left Stabilizer Abrasion Boot.
  - H. Start from the inboard side of the horizontal stabilizer and attach the 0732042-3 Left Stabilizer Abrasion Boot to the horizontal stabilizer. Remove any air that is caught between the 0732042-3 Left Stabilizer Abrasion Boot and the horizontal stabilizer.
  - I. Use a roller or equivalent tool to push down firmly on the surface of the 0732042-3 Left Stabilizer Abrasion Boot.
  - J. Do Steps 4G thru 4I again for the 0732042-4 Right Stabilizer Abrasion Boot.
5. Do a paint touch-up as necessary around the 0732042-3 Left Stabilizer Abrasion Boot and the 0732042-4 Right Stabilizer Abrasion Boot.
  6. Remove maintenance warning tags and connect the airplane battery.
  7. Make an entry in the airplane logbook stating that this Modification Kit has been installed.

B5898

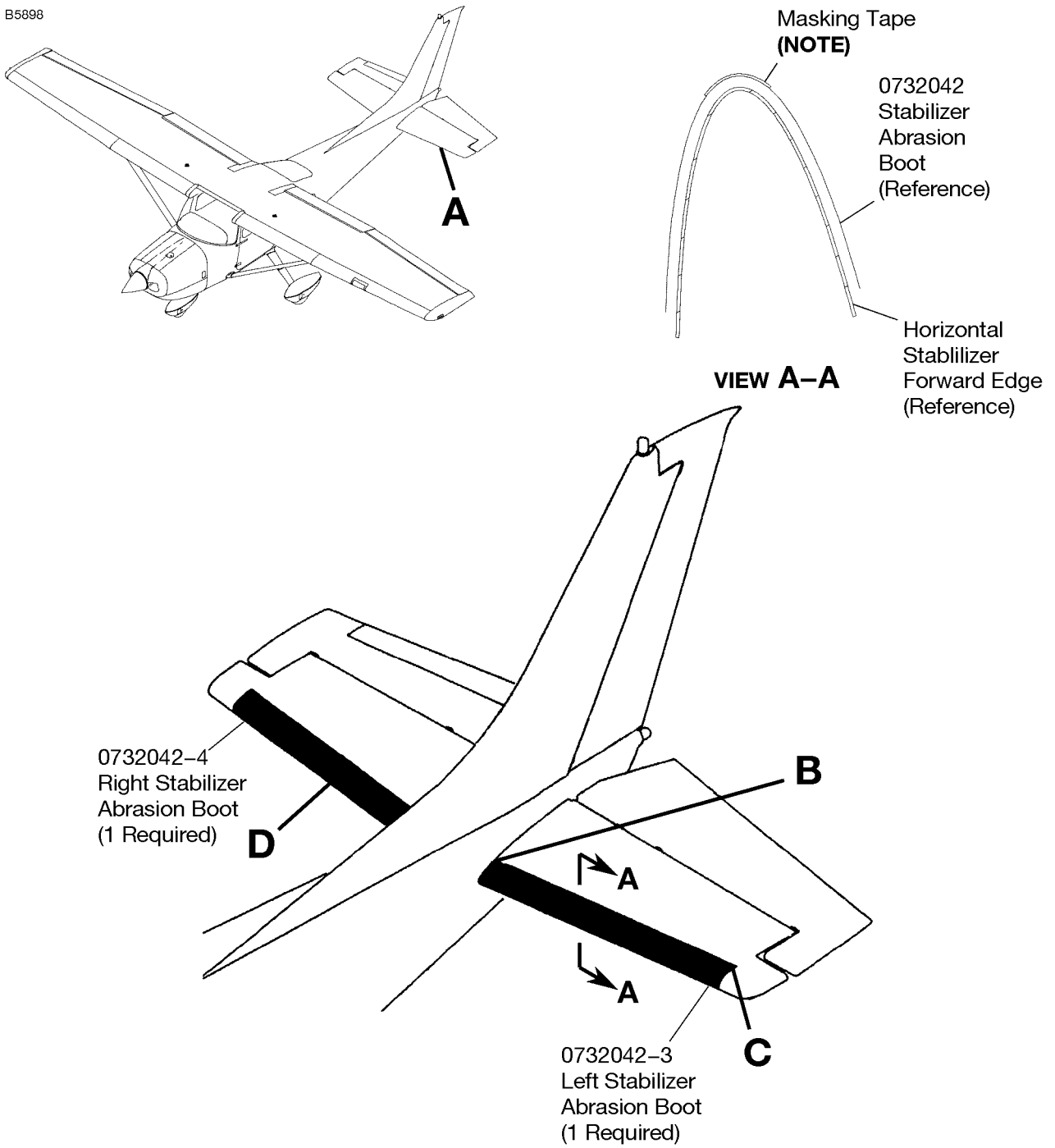

**NOTE:** Put masking tape on the centerline along the full length of the 0732042 Stabilizer Abrasion Boots.

### DETAIL A

Figure 1. Horizontal Stabilizer Abrasion Boot Installation (Sheet 1)

0710T1001  
A0710T1001  
AA0732T042

0732614  
Stabilizer  
Leading Edge  
Fairing  
(Reference)

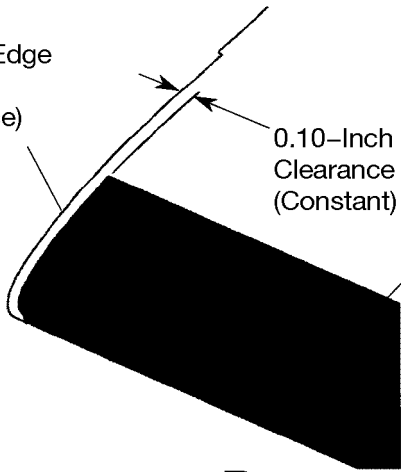

0.10-Inch  
Clearance  
(Constant)

0732042-3  
Left Stabilizer  
Abrasion Boot  
(Reference)

**DETAIL B**  
Inboard View

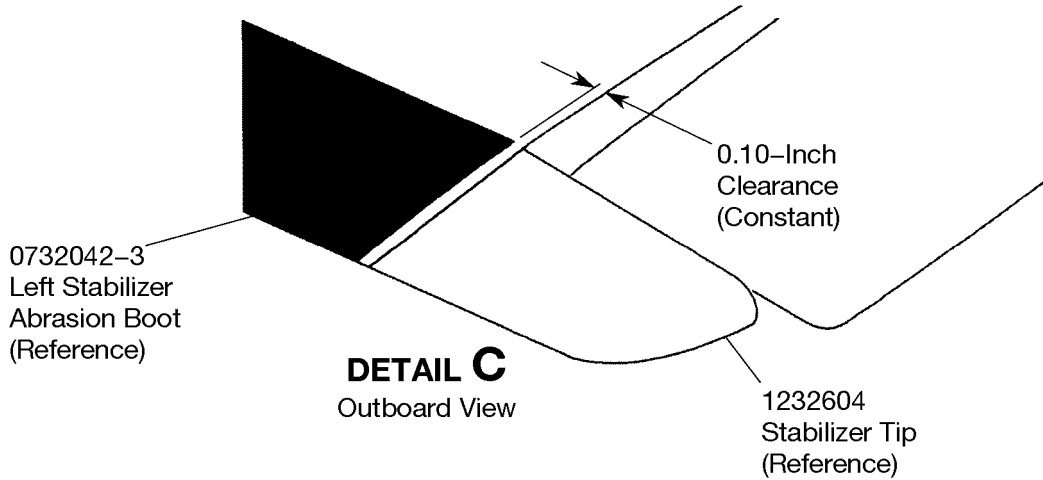

0.10-Inch  
Clearance  
(Constant)

0732042-3  
Left Stabilizer  
Abrasion Boot  
(Reference)

**DETAIL C**  
Outboard View

1232604  
Stabilizer Tip  
(Reference)

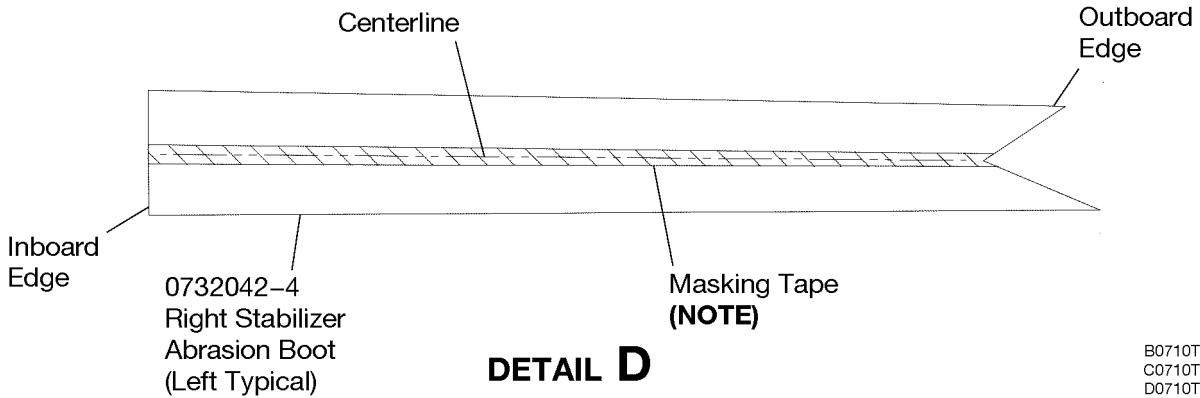

Centerline

Outboard  
Edge

Inboard  
Edge

0732042-4  
Right Stabilizer  
Abrasion Boot  
(Left Typical)

Masking Tape  
(NOTE)

**DETAIL D**

B0710T1001  
C0710T1001  
D0710T1001

Figure 1. Horizontal Stabilizer Abrasion Boot Installation (Sheet 2)