

PS ENGINEERING[®] INCORPORATED

Sound Quality. Sound Engineering.



**9800 Martel Road
Lenoir City, TN 37772
(865) 988-9800 FAX (865) 988-6619
www.ps-engineering.com**

PM500EX

**Low Cost 4-Place
Panel Mounted Intercom
Operator's and Installation Manual**

For use in Experimental/LSA/Non-certified aircraft ONLY
Not intended for installation in aircraft with standard airworthiness certification
The product warranty is not valid unless this product is installed by an
Authorized PS Engineering dealer, or with a PS Engineering harness.

Document Number 200-118-0100
April 2011

Introduction

Congratulations on your purchase of a PM500EX intercom! We at PS Engineering welcome you to our family.

The PM500EX is a panel mounted, 4-place intercom that offers an intelligent low cost alternative for budget minded pilots who still want quality sound and performance. This manual provides information on the installation and operation of the PM500EX. Please read it completely before installation to reduce the risk of damage to the unit and maximize your enjoyment of its use.



Description

The PM500EX is a 4-place, panel-mount intercom with individual output amplifiers for the pilot, copilot, and passengers 1 & 2. The VOX (Voice Activated Squelch) circuit prevents mic audio from getting through the intercom until someone speaks and automatically opens the circuit. The volume control adjusts the level for all headsets and functions as a PUSH-ON/PUSH-OFF power switch.

The PM500EX has an automatic, fail-safe connection to the aircraft radio. In the event that power to the intercom is lost, an internal relay will immediately connect the pilot's headset directly to the aircraft radio.

A provision for an entertainment input allows the pilot and passengers to listen to music during flight. During intercom activity, this music automatically mutes to allow communications without distraction. Note: the music is NOT muted during radio reception.

The 2-position switch acts as a mode selector. In the down position, the intercom is in the ALL mode. Each position will hear the aircraft radio, music, and each other. In the up position, (ISO mode) only the pilot is connected to the aircraft radio for undisturbed radio communications. In ISO, the pilot is no longer on the intercom. All others will continue to communicate with each other and listen to music if desired.

With the PM500EX, both the pilot and copilot have radio transmit capabilities. Only the person who presses their Push To Talk (PTT) will be heard over the aircraft radio. If both pilot and copilot press the PTT, the copilot will override. The pilot regains prior-

ity by switching the unit off.

Specifications

Input power: 12-28 Volts DC
 Current Drain: < 70 mA Externally fused at 1 Amp
 Headphone Impedance: 150-1000 Ω Typical
 Total audio power available: 225 mW
 Audio Distortion: <10% @ 75 mW into 150 Ω load
 Aircraft Radio Impedance: 1000 Ω Typical
 ± 3 dB Mic Frequency Response: 350 Hz-6000 Hz
 ± 3 dB Music Frequency Response: 200 Hz - 15 kHz
 Net weight: 8.5 Ounces (.340 kg)
 Dimensions: 0.90" H X 2.60" W X 4.85" D
 (2.2 cm x 6.6 cm x 12.3 cm)

FAA Approval – NONE

The PM500EX is not intended for installation in aircraft with a standard airworthiness certification.

Installation

The PM500EX was carefully inspected mechanically and thoroughly tested electrically before shipment. It should be free electrical or cosmetic defects. Upon receipt, verify that the parts kit contains the following:

- Two # 4-40 Black machine screws
- Two black knobs with white lines
- One 15 pin Sub-D female connector with hood
- Two connector thumbscrews
- One horizontal face label
- One vertical face label

1. Drill five holes as indicated in a location convenient to the pilot position(s).
2. Once the holes have been drilled, insert the PM500EX from behind the instrument panel through the holes for the knobs and switch.

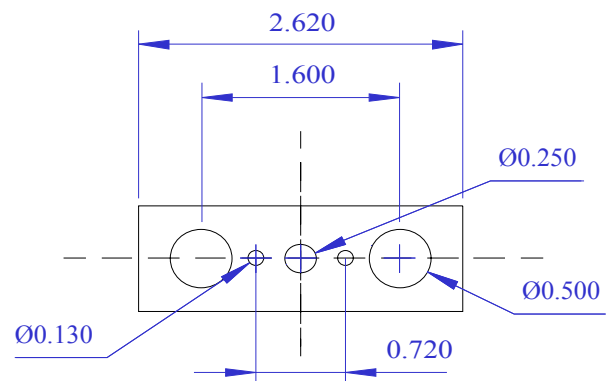

Hole placement diagram (NOT TO SCALE)

NOTE: Do *not* remove the nuts from the volume and squelch controls.

3. Depending on the panel thickness (< 0.040") you may elect to use a locally fabricated aluminum faceplate to provide additional support. Place the aluminum plate over the knob shafts, and secure with the #4-40 screws provided.
4. Next install the two knobs by pressing them on the shafts.
5. Remove the backing from either the vertical or horizontal face label, carefully align over the knob shafts, and press on firmly.
6. To complete the installation, a wiring harness must be made and routed as shown at the back of the manual.

IMPORTANT: You must use separate shielded cable for the microphone and headphone jacks. Combining these two wires WILL cause loud feedback and degrade the intercom functions. The cause of the feedback is due to the fact that there is a much larger signal being carried by the headphone wire than the microphone wire. When these two wires are within the same shielded cable, cross-coupling allows the output to get back into the input, causing oscillations to occur.

If the aircraft already has pilot and copilot headset jacks installed, you may re-use the hardware. Remove all wires from the copilot jacks and discard them. **NOTE:** You may elect to use the existing pilot headset jacks as the auxiliary jacks.

To hook the intercom into the system, simply parallel a set of mic and headphone wires from this set of auxiliary jacks directly to appropriate points to the PM500EX. Finally, install a new set of pilot headset jacks and hook directly to the appropriate points to the PM500EX.

NOTE: Auxiliary microphone and headset jacks are **required** for a complete installation. These provide troubleshooting and a back-up access to the aircraft radios.

NOTE: A custom wire harness can be custom made to your specifications by the factory. Call the factory for more details.

Electrical Noise Issues

Due to the variety of radio equipment found in today's general aviation aircraft, there is the potential for both radiated and conducted noise interference. The PM500EX has a power supply designed to reduce conducted electrical noise on the power bus by over 50 dB. Although this is a large amount of attenuation, it

may not eliminate all noise when the amount of noise is excessive. In addition, there must be at least 13.8 Volts DC present at the PM500EX for the power supply to work in its designed regulation. Otherwise, it will not be able to adequately attenuate all noise.

Shielding can prevent radiated noise (i.e. beacon, electric gyros, switching power supplies) however, installation combinations can occur wherein minor interference is possible. The PM500EX was designed in a RFI hardened chassis and has internal bypass capacitors on all input lines. RFI can still cause problems, like low or distorted sidetone, if correct shielding techniques are not observed.

Ground loop noise occurs when there are two ground paths for the same signal, i.e. airframe and ground return wire. Large cyclic loads such as strobes, inverters, etc., can inject audible signals. **Follow the wiring diagram very carefully** to help prevent ground loop potential. Radiated signals are also a factor when low level mic signals are "bundled" with current carrying power wires. **Keep these cables separated as much as possible.**

Mil-spec 2- and 3-conductor shielded wire MUST be used as shown in the installation diagram for proper operation. Use of other types could void the warranty.

It is crucial that you use insulating washers on all microphone and headphone jacks to isolate the audio signal ground from the aircraft ground.

Power Requirements

The PM500EX is designed to work with either 12 or 28 volt DC negative ground systems. The PM500EX must be externally fused with a 1 ampere circuit breaker.

Side Tone

If the aircraft radio does not have sidetone (the ability to hear your voice during radio transmissions) the PM500EX can be modified to provide sidetone for you. Call the factory for details.

Entertainment Hook Up

A low cost entertainment device (CD player, cassette player, etc.) can be connected to the PM500EX. You may want to install a 1/8" connector (not provided) somewhere in the panel so that you can easily connect an entertainment device.

The entertainment will be automatically muted when the ICS becomes active. The "Soft Mute™" feature slowly returns the music to full volume when the

Note: Use the low level (or line) output from any music device to connect to the PM500EX. Maximum input level is 2 V peak-to-peak.

DO NOT USE SPEAKER OUTPUT.
These levels will cause internal damage.

ICS is quiet. NOTE: Aircraft radio reception DOES NOT mute the entertainment.

External Push to Talk Installation

Part of the installation includes the installation of PTT (Push To Talk) switches that allow the use of your aircraft communications radio for transmissions.

There are three configurations that can be used. You select the case that best fits your installation requirements.

NOTE: Only the person who presses their PTT switch will be heard over the radio.

CASE I

PTT built into the pilot and copilot yokes

Simply install the plugs from the headset into the aircraft headphone jacks. Use the yoke mounted PTT to transmit. No other action is required.

CASE II

Built-in PTT on the pilot side only, but copilot transmit capabilities desired.

This configuration requires a *modified* external PTT plugged into the copilot's mic jack. See [Appendix A](#) for modification details. When the copilot's PTT is depressed, this activates an intercom relay that switches the mic audio input to aircraft radio to the copilot.

CASE III

No built-in PTT switch at all

If there is no built-in PTT switch at all, an external, properly modified PTT switch is required. Both the pilot and copilot may use an external PTT. (See Appendix A.)

OPERATING INSTRUCTIONS

With the installation complete, turn the PM500EX on pressing the volume control knob (left knob). This also engages the automatic fail-safe system.

Adjusting The Volume

The volume control knob adjusts the loudness of the intercom and music for all headsets. Turning the control clockwise increases the audio. Many headsets have volume controls on them. If it becomes necessary to reduce the volume for an individual passenger, the three others should be set at maximum, and the unit

NOTE: In the event of a power failure to the PM500EX, or if the power switch is turned off, the copilot will not hear the aircraft radio. Only the pilot is connected to the aircraft radio.

Volume control, turn CW to increase

volume set for a comfortable level. The individual can then reduce their volume accordingly.

Mode switch

VOX Squelch, turn CW to increase the amount of voice necessary to open



PM500EX Front Panel Controls

The radio volume is not affected for the by the PM500EX Volume Control. This gives added flexibility for communications requirements. **Note:** Unit volume is not affected by plugging in other headsets.

Adjusting The Squelch Control

This VOX operated intercom keeps all microphone channels off while the pilot, copilot or passengers are not speaking. This reduces background noise from the aircraft. Only when someone speaks will their microphones automatically turn on, passing the audio through the system.

Set the Squelch control knob by slowly rotating the squelch knob clockwise until you no longer hear the engine noise in the earphones. When the microphone is positioned properly near your lips, normal speech levels should open the channel. When you stop talking, there is a delay of about a second before the channel closes. This prevents closure between words and eliminates choppy communications.

Mode Select

The center switch is a 2- position mode switch that allows the pilot to tailor the intercom function to best meet the pilot's needs. Regardless of configuration, the pilot will always hear the aircraft radio.

ISO (Up Position): The pilot is isolated from the intercom and is connected to the aircraft radios only. He will hear only the aircraft radio reception and sidetone (only during radio transmissions). Copilot and passengers will hear the intercom and music but not the aircraft radio receptions or transmissions.

All (Down position): All parties will hear the aircraft radio reception and transmissions, intercom, and music. However, during any intercom activity, the music volume automatically decreases. The music volume increases gradually back to the original level after communications have been completed.

The radio traffic will not mute the music.

NOTE: When either the pilot or copilot PTT is depressed, all microphones are off except for the transmitting one.

Warranty

PS Engineering, Inc. warrants this product to be free from defect in material and workmanship for a period of one year from the date of sale.

Installation must be made by an authorized PS Engineering dealer, or the installer must use a PS Engineering harness in order for the warranty to be valid.

During the warranty period, the unit must be returned to PS Engineering, Inc. and, at their option, it will send a replacement at no charge. The customer is responsible for shipping charges returning the unit to PS Engineering.

This warranty is not transferable. Any implied warranties expire at the expiration date of this warranty. WE SHALL NOT BE LIABLE FOR INCIDENTAL OR CONSEQUENTIAL DAMAGES. This warranty does not cover a defect that has resulted from improper or unreasonable use or maintenance as determined by us. This warranty is void if there is any attempt to disassemble this product without factory authorization.

This warranty gives you specific legal rights, and you may also have other rights which vary from state to state. Some states do not allow the exclusion of limitation of incidental or consequential damages, so the above limitation or exclusions may not apply to your state.

Service

Call PS Engineering, Inc. at (865) 988-9800 and ask for a technician. He may be able to diagnose the problem and offer a solution without the possible need for returning the unit. If the unit does need servicing, call the factory to obtain a return authorization. Ship product in UPS approved packaging to:

PS Engineering, Inc.
Attn.: Service Department
9800 Martel Road
Lenoir City, TN 37772
Phone: (865) 988-9800
FAX (865) 988-6619

After the warranty period, PS Engineering offers a low flat-fee repair for the life unit. Contact the factory for details.

PS Engineering is not responsible for units shipped US Mail.

If no RMA, telephone number or method of pay-

ment is provided, the units will be returned COD.

Appendix A

PTT Modifications

When received from the manufacturer, after-market PTT switches open the microphone audio path to the "ring" connection of the PTT mic plug. When the PTT is between the intercom and the headset, the intercom function will not work until the PTT switch is depressed. A simple modification can be performed to allow proper intercom operation. NOTE: This modification does not alter normal operation.

Procedures For David Clark's PTT

- 1 Unscrew the round black plastic cover from the jack.
- 2 Connect the joined black wires to the red wire.
- 3 Replace the round black plastic cover.

Procedures for the Telex's PT-200

- 1 Unscrew the round black plastic cover from the jack.
- 2 Cut the red wire in the middle of the wire
- 3 Strip both ends of the insulation
- 4 Solder the two ends to the ground lug to the PTT jack
- 5 Replace the round black plastic cover

Procedures for the Telex's PT-300

- 1 Unscrew the round black plastic cover from the plug jack
- 2 Remove the heat shrink material from the joined black wires
- 3 Solder these two wires to the lug that has a white already soldered to it.
- 4 Replace the round black plastic cover

These instructions represent typical after-market switches. for more information, contact the manufacturer.

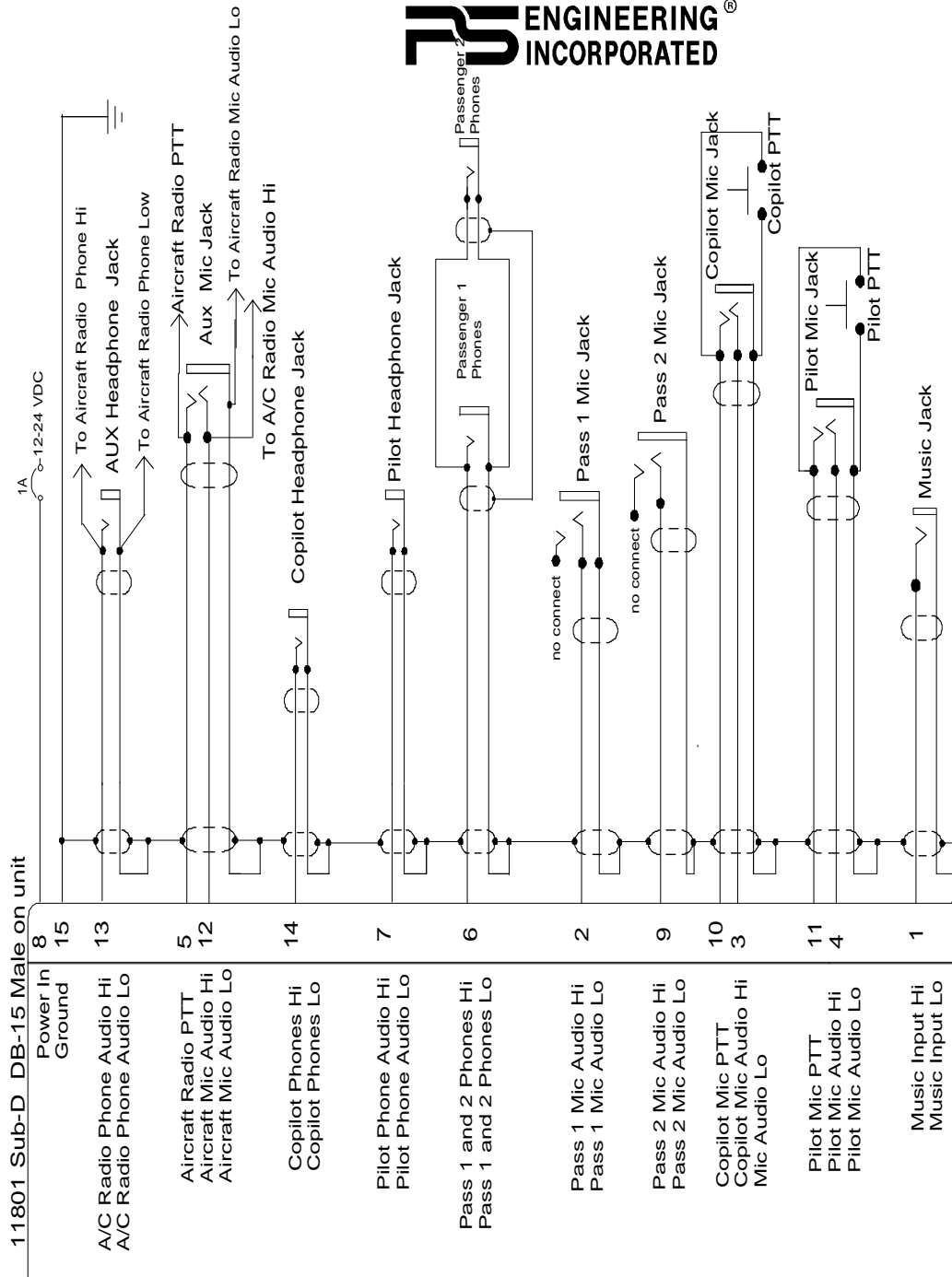

- NOTES:
1. All wire must conform to MIL-22759 or 27500. Minimum 24 gage shielded wire.
 2. Use 2-, and 3-conductor with shield as indicated.
 3. Use insulating washers on all jacks.
 4. Connect shields at intercom end only
 5. AUX headphone and microphone jacks are required.

Connector as viewed from instrument panel

